

Installation and Maintenance Manual
Imtra 150 watt HID Hull light

Model No: ILIM83000

INDEX

1)	General	page 3
2)	Basic Features	page 3
3)	Additional Features	page 4
4)	Specifications (Fixture & Lamp Assembly)	page 5
5)	Specifications (Ballast/Control Gear).....	page 5
6)	Fixture Installation	page 6
7)	Installation of Ballast/Control Gear Unit.....	page 7
8)	Operation and Maintenance	page 8
9)	Replacing the Lamp	page 9
10)	Other Maintenance.....	page 10
11)	Parts and Accessories	page 11
12)	Safety and General Information.....	page 11
13)	Troubleshooting	page 12
14)	Limited Warranty	page 12

1) General

This underwater light has been carefully designed to provide a versatile product of the highest quality, suitable for a wide range of underwater applications such as marine, industrial and domestic.

WARNING! Sections in this manual identify safe practice. It is of the utmost importance that this manual is carefully read and understood. Failure to do so may result in electric shock, injury, fire, or equipment damage. **PLEASE READ CAREFULLY** and, if in doubt, seek professional advice.

2) Basic Features

- **Light source:** The light fixture has been carefully designed to take a 150Watt ballast driven HID (Metal Halide Short Arc Lamp) with color range options between 4,700K and 7,000K (7,000K standard unless otherwise specified).
- **Ballast/Control Gear:** The specially designed ballast and control gear electronics are housed in a water-resistant cast aluminum case. This unit, while providing the necessary starting and running voltages for the lamp, also performs a number of important functions:
 - a) A mains on-off switch
 - b) Power on and alarm indication
 - c) A socket for the connection of optional remote control
 - d) High temperature shut down control for the lamp assembly
 - e) Short Circuit protection of the lamp.

The Lamp and ballast assembly is fitted with purpose-designed industrial flexible mains power cable of 12' (4 mt), and a lamp cable made of high temperature silicone rubber also 12' (4 mt) for remote mounting of ballast/control gear. The ballast/control gear is manufactured from the best materials available carrying the appropriate international certifications.

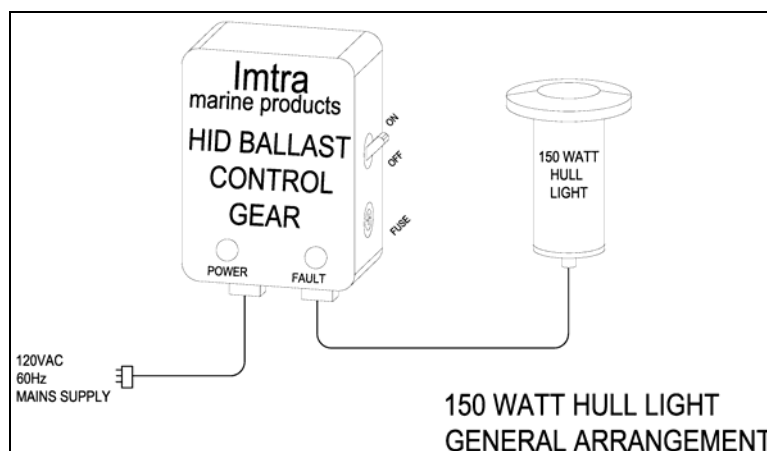

3) Additional Features:

- **Lamp Replacement:** The unit features rear access allowing simple replacement of lamps without removing the fitting.
- **Thermal Management:** The housing has been carefully designed with internal air gap and special venting/convection to direct heat away from that part of the housing in contact with the boat hull or other mounting surface. The housing locking ring has also been designed as a heat sink to further dissipate heat effectively away from where it is not wanted.
- **Over Temperature Protection:** The lamp assembly is fitted with a specially calibrated temperature sensor. This sensor will detect over temperature in the lamp assembly head (such as may be experienced if the lamp is turned on or left on out of water). This sensor will shut the system down until the fixture sufficiently cools down (minimum 30 minutes) then automatically resets. The high temperature cutout circuit also features an alarm indication and (optional) audible alarm.
- **Lamp Housing:** The lamp housing is manufactured from cast 316 stainless steel, machined to the highest standards and electro-polished for added protection. The construction of the unit is such that the front bezel section can be unscrewed to allow fitting of bezels of different materials to suit different situations. For example the bezel being exposed to a range of different liquids, from salt water to harsh chemicals may call for different bezel materials such as 316 stainless steel, Silicone Bronze, Bronze/Aluminum or even Titanium. This can be done without changing the entire body.
- **Seals:** All the seals are of high temperature silicone rubber for reliability.
- **Lens:** The lens is made from heat-treated toughened glass (15mm thick) to cope with high temperatures and a harsh environment. Optional ground lenses can be special ordered which provide different beam angles. The lens is fully replaceable. Colored lenses will also be made available in the future (please ask for details).
- **Installation:** The fixture is supplied with user friendly fixing hardware provided. There is an optional mounting leveling ring available to allow fitment where the inner surface may not be parallel to the outside surface.

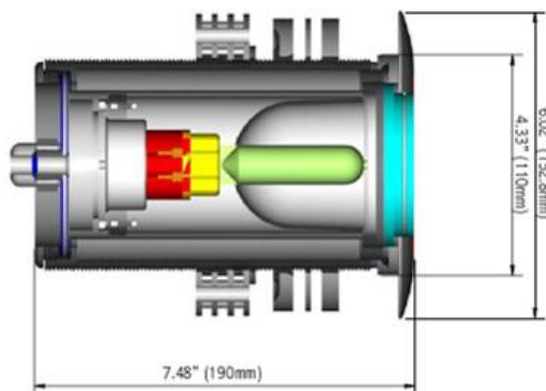

4) Specifications (Fixture & Lamp Assembly):

- Body: 316L stainless steel
- Lens Bezel: 316L stainless steel standard (other materials available on request)
- Lens: Toughened heat-treated glass, 15mm thick
- Seals and Gaskets: High temperature (200 deg. C) silicone rubber.
- Lens Securing Friction Ring: Teflon (PTFE)
- Lamp Cable: High temperature (200 deg. C) silicone rubber insulated, sheathed cable screened to reduce RF interference
- Fixture Weight: 5.2Kg
- Dimensions: Insertion length 7" (180mm), body diameter 4.1" (106mm), lens bezel overall diameter 6" (153.5mm)
- Cutout Size: 4.33" (110mm)
- Maximum Hull Thickness: 5" (125mm)
- Minimum Hull Thickness: 0.25" (6mm)
- Water Ingress Protection Rating: IP66
- Lamp Details: The light has been carefully designed to take a 150Watt ballast driven HID (Metal Halide Short Arc Lamp). Color temp: 7,000 Kelvin. Luminous flux: 12,000 lm. Color rendering index: Ra > 85 (Recommended lamp fitted is OSRAM model HSD150/70 as fitted).

5) Specification (Ballast/Control Gear) ELECTRICAL

- Mains input voltage: 120Vac 60 Hz (240Vac 50Hz available on request)
- Mains current draw: 1.4 amps
- Power factor: 90%
- Lamp output starting (ignition) voltage: 4Kv
- Lamp running voltage: approx 97V
- High temperature cutout: Fitted
- High temperature alarm: Fitted
- Mains On-Off switch: Fitted
- Short Circuit Protection: Fitted (both lamp and ballast)
- Socket for (Optional) low voltage (12Vdc) remote control and indicator. A remote control panel and harness to be available in the future. Please ask for availability.

HOUSING

- Ballast housing: Cast Aluminum (epoxy coated)
- Size: 11 in. x 9 in. x 3.5 in. (280mm x 230mm x 90mm)
- Hinged cover

- Weight: 11.5 Lbs (5.25Kg)
- Rating: IP56
- Fittings: Mains ON/OFF switch, Mains Fuse, Power ON indicator, Fault Indicator and Remote control socket.
- Labeling: Operation and Warning label fitted to outside of cover with wiring diagram fitted to inside of cover.
- Cable entries: Glanded.

6) Fixture Installation

a) The Lamp assembly requires a 4.33" (110mm) minimum diameter hole (Note: The hole diameter is deliberately larger than the housing to provide an air gap between the housing and the hull. This void should not be filled with sealant.). The hole should be cut using the best quality, appropriately designed hole saw to ensure the hole is cut without damage to adjacent surfaces.

IMPORTANT! The housing must be located at a minimum of 10 in. (250mm) below the water line to ensure the unit is continuously covered with water, providing the necessary cooling.

b) The cut surface of the hole should be sealed carefully to prevent moisture from penetrating the exposed laminations. High temperature marine-grade polysulphide or silicone may be used.

c) Once the hole is prepared, apply a generous, continuous even bead of quality marine-grade sealant into the groove under the lens bezel flange. High quality polysulfide adhesive/sealant or high-temp silicone sealant is acceptable. Many professionals recommend 3M (polyurethane) 4200 Fast Cure adhesive/sealant. Apply a second thinner bead continuously around the flat inner surface of the lens bezel.

d) Carefully insert the Lamp housing into the Hull (or other wall structure).

e) Apply sealant on inside hull surface just around the hole cut-out (see diagram).

f) Fit the silicone washer.

g) Fit the stainless steel washer.

h) Fit the locking ring and tighten. We recommend using 2 filter wrenches (available at any auto parts store) to tighten the locking ring while simultaneously holding the housing stationary.

i) Once tightened, excess sealant may be removed from around the bezel.

j) Connect the grounding wire to the housing via one of the 4 threaded holes in the housing locking ring, using an appropriately sized 316 Stainless steel bolt and cable lug.

Note: For uneven inner surfaces an optional floating leveling ring kit (#ILIM82053) is available, however the installation procedure for the housing remains the same.

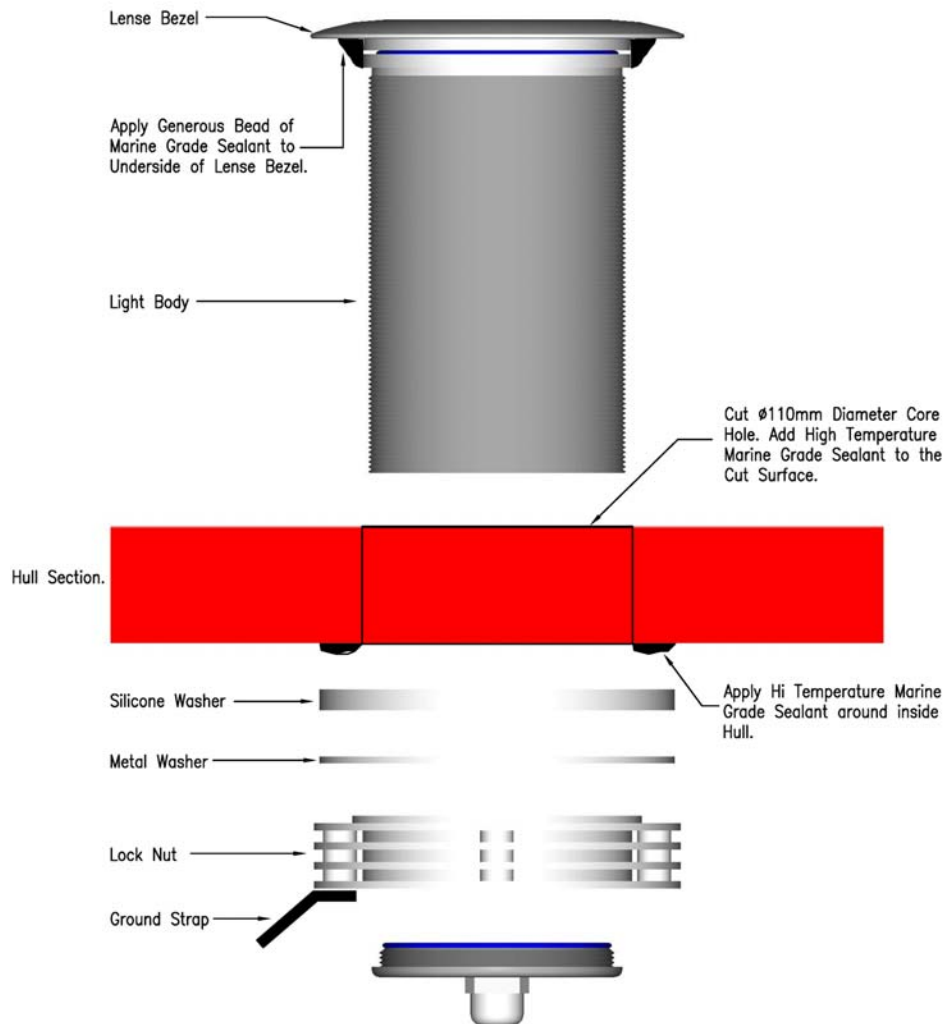

7) Installation of Ballast/Control Gear Unit

Although contained in a water-resistant enclosure, the ballast/ control gear unit should be mounted well away from wet areas. It should be mounted in a ventilated, dry, and accessible location where it can be checked regularly and operated easily if no remote control is used. The housing has been supplied with external mounting points. **DO NOT** drill holes through the casing to mount. The mains power cord must be lead through safe & secure areas, away from motors, mechanical (moving) machinery, and away from sensitive electronics. It must be secured & supported neatly along its entire length. Do Not Coil excessive cable as inductive heating may result (this applies to any power cable). If there is excessive cable, simply run it back along its self in parallel. The unit has been supplied with all cables terminated and tested.

Should it be necessary to disconnect the cables to route same, then this must only be carried out by a suitably qualified technician, observing carefully the terminations.

Note: The mains power must be a 3 wire solidly grounded system with the ground (Earth) connected the to the vessels mains shore power and generator ground.

WARNING: At no stage should the cabinet be opened while the unit is energized as dangerous voltages are present. All testing **MUST ONLY** be carried out by suitably trained and qualified technicians. **DO NOT** attempt to open the lamp housing without isolating the power, as although the lamp may be out, there still may be dangerous voltage present. Always isolate power before changing bulbs. **IF IN DOUBT, SEEK ADVICE.**

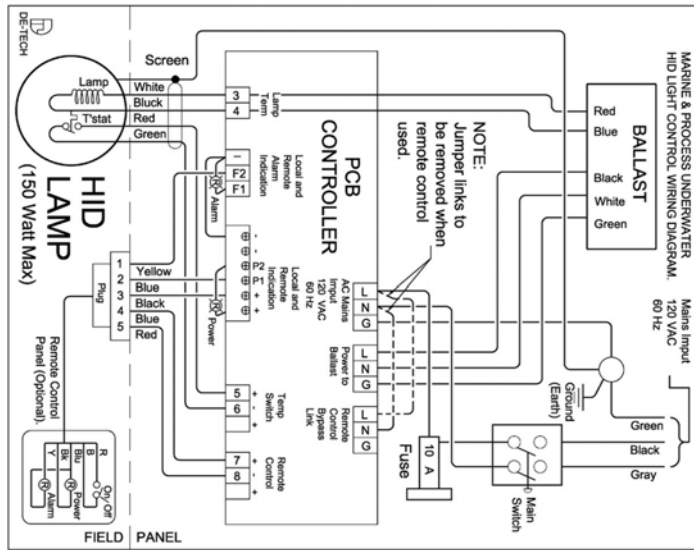

8) Operation and Maintenance

- The lamp assembly is fitted with a specially calibrated temperature sensor. This sensor will detect over temperature in the lamp assembly head (such as may be experienced if the lamp is turned on or left on out of water). This sensor will shut the light down until such time as the light has sufficiently cooled down (minimum 30 minutes) then automatically reset. Depending on ambient temperature, reset may take longer. The high temperature cutout circuit also features an alarm indication and (optional) audible alarm.
- **NOTE:** In the event of high temperature cutout the unit should be switched off.
- **WARNING:** Never operate the light out of water as the water provides necessary cooling. The lens bezel must be completely submerged at all times. Avoid operating the light when the boat is planing as often times this raises the fixture bezel above the water-line and thus diminishing the cooling effect of the water.
- Operating the light: As with all discharge type lamps, they take time to warm up and reach full brightness (about 5 minutes). When the light has been running and

switched off it will not restart immediately, it will need to cool down before restriking. This can take up to 10 minutes.

- Generally, discharge lamps have a service life of approximately 2,000 –3,000 hours. This may vary depending on the number of restarts and other factors.

9) Replacing the Lamp:

- Isolate mains power and assure it can not be re energized accidentally by other persons.
- Allow the lamp and housing to cool down (minimum 20 minutes). Check carefully that the unit has cooled sufficiently before attempting to open the housing.
- Using the special tool provided, loosen the rear lock ring, (turning counter clockwise).
- Once the ring is free, carefully withdraw the lamp assembly from the housing.
- NOTE: Ensure the area local to the light is relatively dry, thus ensuring bilge water can not enter the opened housing. Also ensure the withdrawn lamp assembly DOES NOT come in contact with water at any time. It MUST remain clean and dry at all times. Should the assembly come in contact with water, contact your nearest supplier for further advice. Do not re-assemble and re-energize.
- Hold the cable end of the lamp assembly and rotate (counter clockwise) the reflector case. Unscrew until the lamp is exposed.
- Carefully withdraw the spent lamp from its socket. It is recommended to use a glove or thick cloth as the lamp may shatter causing injury.
- Inspect the lamp socket carefully for any signs of damage or corrosion. Basic cleaning may be carried out using dried, compressed air. DO NOT spray contact cleaner into any part of the lamp holder assembly.
- Carefully remove new lamp from its packing. Using a clean cloth, fit the new lamp into the socket. IMPORTANT! Ensure the new lamp is wiped totally clean of any dirt or fingerprints. Failure to do so will result in premature lamp burn-out.
- Refit the Aluminum reflector case to the base of the lamp assembly ensuring it is tight (Hand tighten only). It is recommended to wipe a thin layer of Lanolin based grease only around the edge of the lamp base in contact with the red silicone seal.
- Inspect the housing to ensure it is completely clean and dry. The lens may be cleaned if necessary using a soft cloth on the end of a wooden dowel or similar. Re inspect after cleaning to ensure no cloth or other cleaning fibers remain inside the housing. NEVER! Spray lubricants, degreasing agents or other similar products into the housing.

- Carefully re-fit the lamp assembly into the housing ensuring the front end of the reflector case locates correctly into the front end of the lamp housing. This can be felt by moving the assembly around until it drops neatly into position with the rear end cap snug against the silicone seal.
- Re-fit the outer lock ring. Again it is recommended to apply a thin layer of Lanolin based grease to the thread and surface in contact with the end cap.
- Tighten the locking ring using the tool provided ensuring it is TIGHT.
- NOTE: at no point is it necessary to loosen the cable gland nut, however it should be checked to ensure it is secure and snug around cable, DO not pull excessively on the cable.

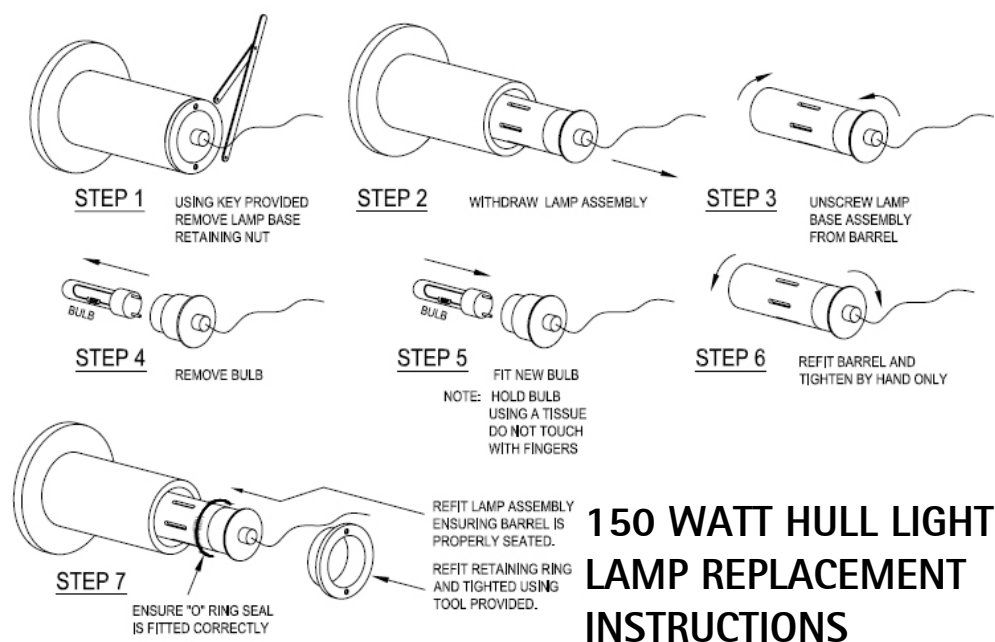

10) Other Maintenance:

- Check to ensure the underwater lens is clean and free of marine growth, this may be cleaned using a nylon brush or plastic scraper.

(Refer to lamp changing diagram below)

- Fuse replacement: The ballast housing is fitted with an externally accessible fuse, located on the side of the housing adjacent to the mains power switch. If blown, replace with a 3 amp fuse. Ensure power is isolated before changing the fuse.
- Replacement parts and accessories: A full range of Replacement parts and accessories are available. Please contact your supplier for any requirements.
- Ballast/Control gear: There are NO serviceable parts inside the Ballast Housing. Should there be a malfunction for any reason please consult your nearest agent or

Imtra directly. The housing should not be opened under any circumstances unless by a suitably qualified and authorized technician.

11) Parts & Accessories

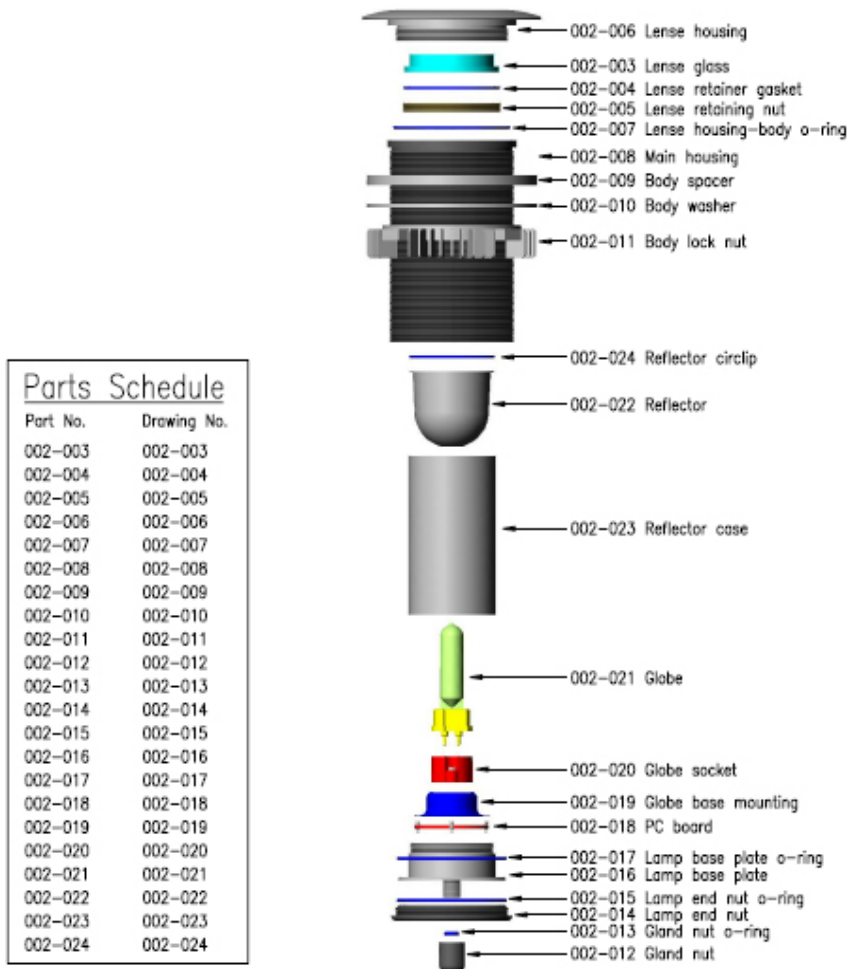

12) Safety and General Information

THE FOLLOWING INFORMATION IS IMPORTANT TO THE SAFE OPERATION OF THIS EQUIPMENT, ACCORDINGLY MUST BE OBSERVED AND ACTIONED AS NECESSARY.

- This Light should only be installed by suitably trained trades persons experienced in the fitting of through hull equipment and marine Mains Voltage AC electrical systems.
- This equipment requires a 3 wire solidly grounded (earthed) 120VAC supply. For Safe operation the mains supply **MUST** be grounded to the Shore Power and On Board Generator Grounding system.
- This light must only be operated when fully submerged. Special attention should be paid when fitted to transom sections as when the vessel is planning this area may be out of the water.

- It is important that the housing is electrically bonded to the vessels cathodic protection grounding system. Failure to solidly ground will result in corrosion, leading to serious damage or loss of vessel, property and life. Regular checks/testing must be carried out to ensure the metal housing is electrically bonded to the vessels cathodic protection grid.
- If the housing shows signs of excessive corrosion (other than surface contamination) or physical damage, the vessel should be hauled so a complete assessment can be performed. Any signs of water ingress must be addressed immediately.
- As this equipment operates on mains voltages, it is of the utmost importance that all equipment is maintained in first rate working order at all times. Regular inspections should be carried out to ensure all wiring is in good condition, clear of wet areas and not exposed to mechanical interference.
- Cabling between the ballast/Control gear must be located away from wet areas and well protected against damage.
- Any suspect equipment must be repaired or replace.
- The Lens and Bezel have been carefully designed with a smooth, flush surface to allow easy cleaning.
- The lens must be free from marine growth at all times and kept clean. Failure to do so will see excessive heat build up in the lamp housing and premature failure of the lamp. It is recommended to clean the lens prior to each operation. Lens may be cleaned using a sponge or soft nylon brush. A plastic scraper may be used for more stubborn growth.
- Never operate the vessel with the lamp housing end cap removed.

13) Troubleshooting

When lamp fails to start, please check all indicator lights	
Power-On Indicator is "Off":	- Check mains power supply
Power-On Indicator is "On":	- Check "Blue" Fault Indicator
Blue Fault Indicator is "On":	- Lamp may be overheated (wait 15-20 minutes and retry) - Lamp needs replacing - Water has breached lamp housing. Disconnect power and inspect lamp housing. If water is present, re-fit end cap and contact service technician.
Blue Fault Indicator is "Off":	- Ballast and thermal overload may have tripped. Wait 15-20 minutes to allow re-set, otherwise lamp may need replacing

14) Limited Warranty

Imtra warrants these fixtures to be free of defects in parts and workmanship for 1-year from the date of shipment. This warranty does not apply to defects resulting from action

of the user such as misuse, improper wiring, operation outside of specification, improper maintenance or repair or unauthorized modification. Bulbs are not covered under warranty as they are a purely consumable item that may be adversely affected by environmental factors beyond our control. *Imtra* specifically disclaims any implied warranties or merchantability or fitness for a specific purpose and will not be liable for any direct, indirect incidental or consequential damages. *Imtra's* total liability is limited to repair of the fixture at our facility in New Bedford or replacement of the product outright.

Under no circumstances is *Imtra* responsible for reimbursement of expenses related to vessel haul-outs, technician or yard personnel travel expenses, yacht storage, labor performed during removal and/or replacement of fixture, or expedited shipping costs for replacement parts. These are assumed liabilities of the customer and part of the terms of sale between *Imtra* and its customer.

The warranty set forth above is inclusive and no other warranty, whether written or oral, is expressed or implied. If it should become necessary to return a fixture for service during or beyond the warranty period, please refer to *Imtra's* standard Return's Policy located in our product binder or call our customer service desk at 508-995-7000. No returns are accepted without a Return Authorization (RA) number.

Imtra Corporation
30 Samuel Barnet Boulevard
New Bedford, MA 02745
Phone: (508) 995-7000
www.imtra.com